

SH-5000 ST

BUFFER
STORAGE TANK

SPECIFICATIONS



The SH-5000 ST. Buffer storage tank, a new addition to the SmartHeat range, a system that provides a great alternative to store large quantities of hot water. The new SH-5000 ST

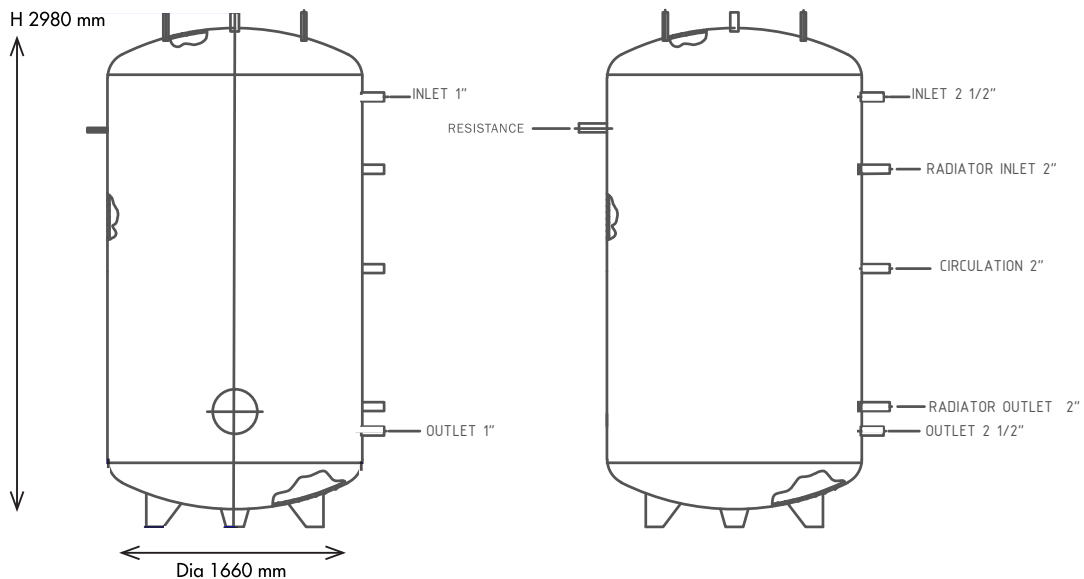

SH-5000 ST BUFFER STORAGE TANK SPECIFICATIONS

CAPACITY:	5000 Litres
INNER TANK: Enamel Tank	2mm
NONE COIL TYPE	0
HEIGHT:	2980mm
DIAMETER:	1660mm
WEIGHT: Empty	1100kg
WEIGHT APPROX: Full	6100kg
OUTER TANK: Vinlex Covering	—
TANK INSULATION: Sponge Insulation	80mm
HEATER: Inlet & Outlet	3"
CIRCULATION:	2"

Applications: Underfloor Heating & Cooling, Solar, Pool/Spa, Domestic Hot Water, Wet Back, Recommended Maximum Temperature 90C.