

SH-300

DOMESTIC HOT WATER
ELECTRICALLY HEATED

SPECIFICATIONS

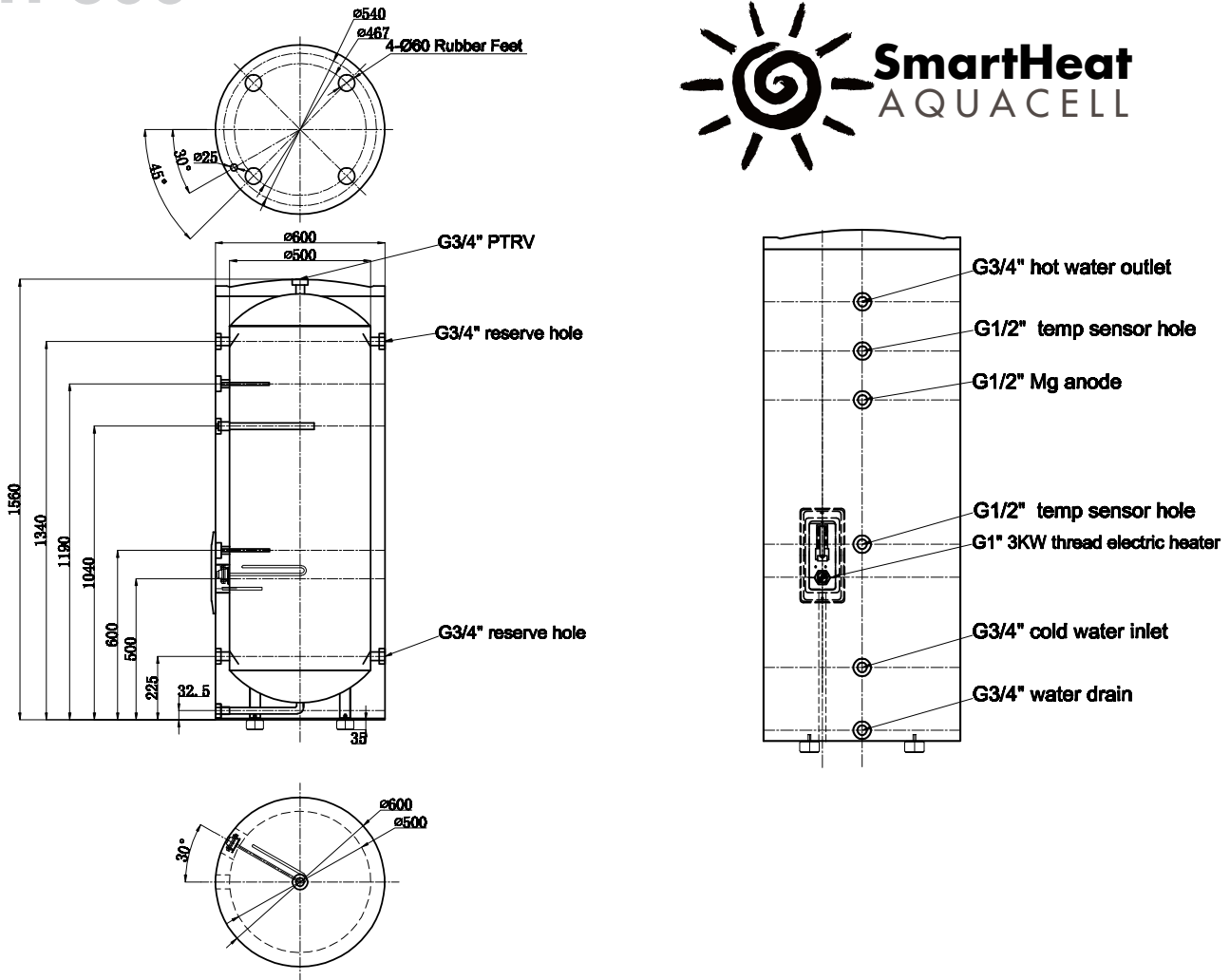



SH-300 THERMAL HEAT EXCHANGE STORAGE SPECIFICATIONS

CAPACITY:	300 Litres
MATERIAL:	Internal 1.5mm
ELECTRIC ELEMENT:	3 kW
INNER TANK: Stainless Steel	304
HEIGHT:	1595mm
DIAMETER:	600mm
WEIGHT: Empty	55kg
WEIGHT APPROX: Full	355kg
TANK INSULATION: Polyurethane Insulation	50mm
OUTER TANK: Normal Steel Painted White	0.5mm

Applications: Domestic Hot Water, Recommended Maximum Temperature 90 C.

AS3498

PHNIX CT No25913



For further information please contact SmartHeat or visit www.smartheat.com.au

SmartHeat 7-26 James Street Lidcombe NSW Australia 2141 - **T:**1300 186 667 - **F:** 02 96439789.